

Ref. : CB 4450.pas

Rev. : A

Date : 03/11/2009

Page : 1/1

WAFER TYPE DUAL PLATE CHECK VALVE

CB 4450



ROBINETTERIE INDUSTRIELLE ET ACCESSOIRES
INDUSTRIAL VALVES AND ACCESSORIES

APPLICATION

General uses: pumping, water supply, gas, air conditioning installation.

GENERAL CHARACTERISTICS

Design in accordance with standard NF EN 12334 and NF EN 14341.
Range: From DN 40 to DN 300.
Mounting between flanges.
Working positions: horizontal and vertical ascending, and vertical descending position < DN 150.
Mounting in accordance with many standards connections.
Low head loss.
Stainless steel spring technology to avoid fluid hammer.

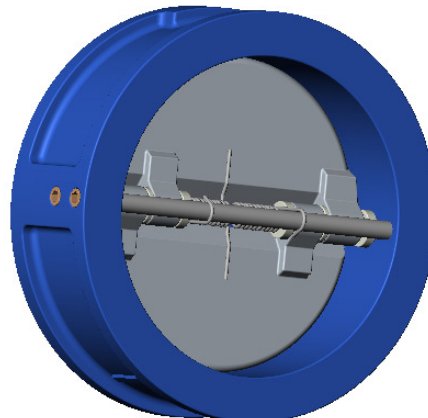

CONSTRUCTION

6	6	Washer	PTFE	
5	2	Stem	Stainless steel	
4	2	Spring	Stainless steel	
3	2	Gasket	EPDM	
2	2	Plate	Ductile iron EN-GJS-400-15	DIN: GGG 40 ASTM: A536 65-45-12 BS: 1563 EN-JS1030
1	2	Body	Ductile iron EN-GJS-400-15	DIN: GGG 40 ASTM: A536 65-45-12 BS: 1563 EN-JS1030
Rep.	Qty.	Description	Material	

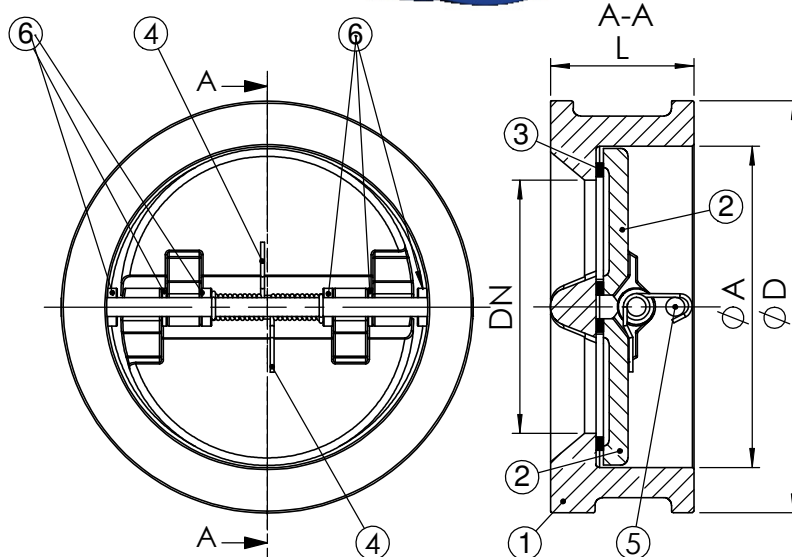

DIMENSIONS

DN		L	Ø A	Ø D	Weight (kg)
mm	inch				
40	1 1/2"	43	65	92	1,9
50	2"	43	65	107	2,2
65	2 1/2"	46	80	127	3,3
80	3"	64	94	142	4,3
100	4"	64	117	168	6,6
125	5"	70	145	194	10,9
150	6"	76	170	224	12,9
200	8"	89	224	284	20,1
250	10"	114	265	341	31,4
300	12"	114	310	401	50,0

WORKING CONDITIONS

Minimum opening pressure : near to zero
Maximum working pressure : 25 bar.
Maximum temperature : +130 °C.

Pressure test according to standards
EN 12266-1, DIN 3230, BS 6755 and ISO 5208 :
Body : 37.5 bar.
Seat : 27.5 bar.

STANDARDS

Manufacture according to the requirements of the European directive 97/23/CE «Equipment under pressure»:
fluids category III modulate H.
Face to face according to standards NF EN 558-1 serie 16 tab11 and DIN 3202 except for DN40 (face to face of DN40 same as DN50).
Mounting between flanges PN25 according to EN 1092-2, ASA 150 lbs on request.

Horizontal
For assembling in horizontal position, check axis as to be placed in vertical position.

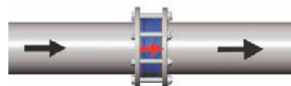

Vertical
To be assembled in vertical position the opening direction of the plates has to be in accordance to the direction of the fluid

