

Ref. : CB 6450.pas

Rev. : A

Date : 04/11/2009

Page : 1/1

WAFFER TYPE DUAL PLATE CHECK VALVE

CB 6450



ROBINETTERIE INDUSTRIELLE ET ACCESSOIRES
INDUSTRIAL VALVES AND ACCESSORIES

APPLICATION

General uses: pumping, water supply, gas, air conditioning installation.

GENERAL CHARACTERISTICS

Gamme : du DN 50 au DN 400
Mounting between flanges.
Working position: horizontal and vertical ascending, and vertical descending position < DN 150.
Low head loss.
Stainless steel spring to avoid fluid hammer.

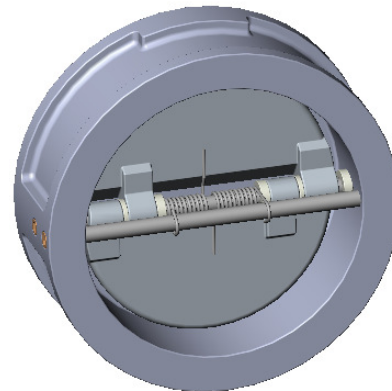

CONSTRUCTION

6	6	Washer	Stainless steel
5	2	Stem	Stainless steel
4	2	Spring	Stainless steel
3	2	Seat	FPM (DN50 – 200) NBR (DN250 – 400)
2	2	Plates	Stainless steel
1	1	Body	Stainless steel
Pos.	Qty.	Description	Material

DIMENSIONS

DN		L	Ø A	Ø D	Weight (kg)
mm	inch				
50	2"	43	56	108	1,2
65	2 1/2"	46	62	128	1,9
80	3"	64	70	143	3
100	4"	64	90	164	4
125	5"	70	110	194	6
150	6"	76	130	220	8,5
200	8"	89	195	275	15
250	10"	114	245	338	On request
300	12"	114	292	402	
350	14"	127	340	460	
400	16"	140	380	514	

WORKING CONDITIONS

Minimum opening pressure : proche de zero
Maximum working pressure : 25 bar.
Maximum temperature : +120 °C (DN50 - 200)
+90 °C (DN250 - 400)

AGREEMENT AND TESTING

Test procedures are established according to NF EN 12266-1, DIN 3230, ISO 5208.
Face to face according EN 558-1 serie 16.
Mounting between flanges PN25 according to NF EN 1092-1.

Horizontal

For assembling in horizontal position, check axis as to be placed in vertical position.

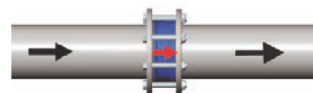

Vertical

To be assembled in vertical position the opening direction of the plates has to be in accordance to the direction of the fluid

