

Ref. : VG 3400-UX4.pas

Rev. : Initial

Date : 04/03/09

Page : 1/2

KNIFE GATE VALVE WITH ELECTRIC ACTUATOR "AUMA"

VG 3400-UX4



ROBINETTERIE INDUSTRIELLE ET ACCESSOIRES
INDUSTRIAL VALVES AND ACCESSORIES

PRODUCT REFERENCE

	REFERENCES	Electric actuator type
<input type="checkbox"/>	VG 3400-U04	AUMA 400V 3 PH
<input type="checkbox"/>	VG 3400-U14	AUMA 230V 3 PH
<input type="checkbox"/>

APPLICATION

General use : Pulp production, water, water treatment, waste water, chemical industry (powdery or crystallizing products), wine-producing, pulverized products (cement work, pneumatic transport, stocking).

GENERAL CHARACTERISTICS

Function ON/OFF or regulation.
Wafer threaded mounting ISO PN10.
Unidirectional tightness, direction indication thanks to the arrow on the body.
Small retention zone: the gate is guided in the body and has little clearance.
Gland assembly: packing and O-ring (same material as seat joint) to assure the elasticity and decrease the operating torque.
Small head loss.
Possibility to regulate thick fluids the adaptation of a diaphragm ring .



CONSTRUCTION

11	1	Electric actuator		AUMA
10**	1	Support ring	Stainless steel 316	DIN : X5CrNiMo18 10 ASTM : A 182 AIS 3 16 BS : 316 S16
9**	1	Gasket	Nitril	
8	1	O-ring	Nitril	
7	1	Packing gland	Aluminium (DN50-450) Acier (DN500-600)	
6	1	Nut support	Painted steel	
5*	2	Support plate	Steel + epoxy	
4	1	Stem	Stainless steel 13%Cr	
3	1	Knife gate	X5CrNi 18-10	DIN : X5CrNi 18-10 ASTM : AISI 304 BS : 304 S15
2	2	Packing	PTFE	
1	1	Body	EN-GJL-250	DIN : GG 25 ASTM : A48 class 40B BS : 1452 Grade 250
Pos.	Qty.	Description	Material	

* Pre-shaped parts up to DN 300.

**Missing parts on metal/metal tightness.

DIMENSIONS

DN	Actuator type	A	B	C	D	E	F	G	Ø V	H	Ø K	n	Ø M	Weight (kg)	
50	2"	SA07.1	40	383	124	83	249	265	237	160	578	125	4	4-M16	27
65	2 1/2"	SA07.1	40	408	139	83	249	265	237	160	603	145	4	4-M16	29
80	3"	SA07.1	50	433	154	83	249	265	237	160	628	160	8	4-M16	30
100	4"	SA07.1	50	478	174	83	249	265	237	160	673	180	8	4-M16	31
125	5"	SA07.5	50	516	189	93	249	265	237	160	711	210	8	4-M16	37
150	6"	SA07.5	60	567	220	93	249	265	237	160	762	240	8	4-M20	41
200	8"	SA07.5	60	686	275	108	249	265	237	160	881	295	8	4-M20	57
250	10"	SA07.5	70	778	326	108	249	265	237	160	973	350	12	8-M20	75
300	12"	SA10.1	70	887	380	108	254	282	247	200	1082	400	12	8-M20	87
350	14"	SA10.1	96	990	438	290	254	282	247	200	1185	460	16	10-M20	138
400	16"	SA10.1	100	1100	494	290	254	282	247	200	1295	515	16	10-M24	168
450	18"	SA14.1	106	1225	547	290	329	384	285	315	1430	565	20	14-M24	234
500	20"	SA14.1	110	1335	613	290	329	384	285	315	1540	620	20	14-M24	269
600	24"	SA14.1	110	1539	716	290	329	384	285	315	1744	725	20	14-M27	313

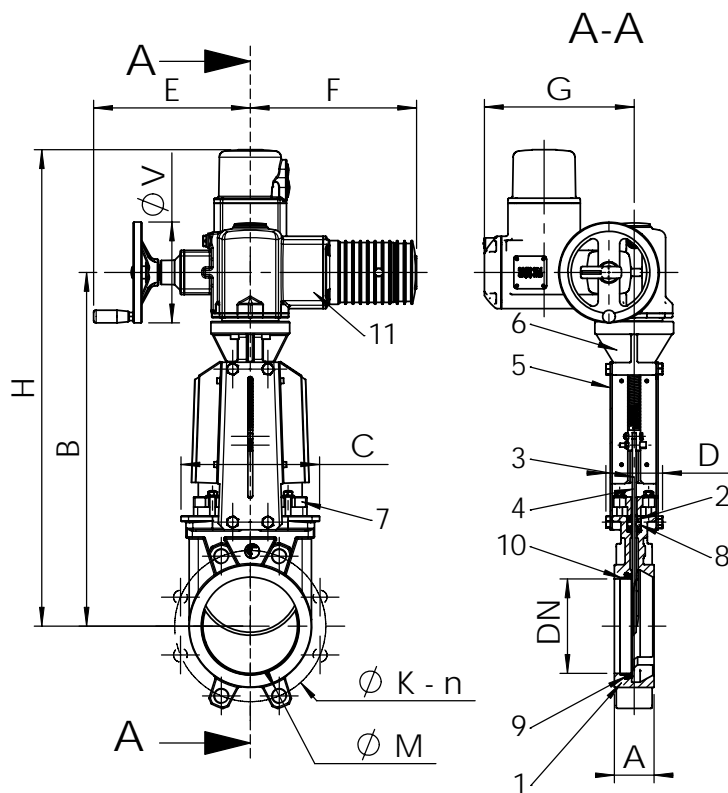

Ref. : VG 3400-UX4.pas

Rev. : Initial

Date : 04/03/09

Page : 2/2

KNIFE GATE VALVE WITH ELECTRIC ACTUATOR "AUMA"

VG 3400-UX4



ISO 9001 : 2000

Certifié par



ROBINETTERIE INDUSTRIELLE ET ACCESSOIRES
INDUSTRIAL VALVES AND ACCESSORIES

WORKING CONDITIONS

Maximum working pressure : DN 50-250 : 10 bar
DN 300-450 : 7 bar
DN 500-600 : 4 bar

Maximum temperature : -10°C / +80°C (Standard tightness)

Others material on request (If marked)	Maximum temperature	
Metal / metal	T max : -10°C / +200°C.	<input type="checkbox"/>
White Nitril	T max : -10°C / +80°C.	<input type="checkbox"/>
EPDM	T max : -20°C / +130°C.	<input type="checkbox"/>
Silicone	T max : -20°C / +170°C.	<input type="checkbox"/>
FPM (Type Viton®)	T max : -10°C / +170°C.	<input type="checkbox"/>
PTFE	T max : +4°C / +170°C.	<input type="checkbox"/>
CSM (Type Hypalon®)	T max : +4°C / +80°C.	<input type="checkbox"/>



Standard tightness

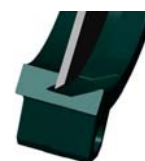

Tightness metal/metal

STANDARDS

Manufacture according to the requirements of the European directive 97/23/CE «Equipments under pressure» : fluids category III modulate H.

Test procedures are established according to standard EN 12266-1, DIN 3230, BS 5154 and ISO 5208.

Connections according to standard EN 1092-2 and DIN 2501 : ISO PN10.