

Ref. : VG 3400-08.pas

Rev. : A

Date : 03/10/08

Page : 1/2

# KNIFE GATE VALVE WITH GEAR BOX

## VG 3400-08



ROBINETTERIE INDUSTRIELLE ET ACCESSOIRES  
INDUSTRIAL VALVES AND ACCESSORIES

### APPLICATION

General use : Pulp production, water, water treatment, waste water, chemical industry (powdery or crystallizing products), wine-producing, pulverized products (cement work, pneumatic transport, stocking).

### GENERAL CHARACTERISTICS

Function ON/OFF or regulation.  
Wafer threaded mounting ISO PN10.  
Unidirectional tightness, direction indication thanks to the arrow on the body.  
Small retention zone: the gate is guided in the body and has little clearance.  
Gland assembly: packing and O-ring (same materials as seat joint) to assure the elasticity and decrease the operating torque.  
Small head loss. Possibility to regulate thick fluids with the adaptation of a diaphragm ring.

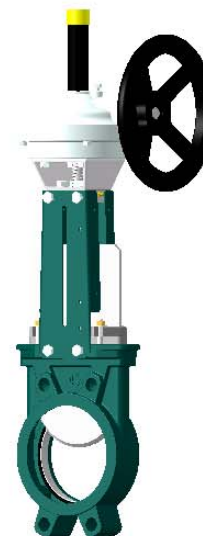

### CONSTRUCTION

15**	1	Support ring	Stainless steel 316	
14	1	Handwheel	Cast iron	
13	1	Gear box	Cast iron	
12	1	Protection tube	Steel	
11	1	Cap	Plastic	
10**	1	Gasket	Nitril	
9	1	O-Ring	Nitril	
8	1	Packing gland	Aluminium (DN400-450) Steel (DN500-1200)	
7	1	Support	Stainless steel	
6	1	Nut support	Zinc steel	
5*	2	Support plate	Steel + epoxy	
4	1	Stem	Stainless steel 13%Cr	
3	1	Gate	Stainless steel X5CrNi 18-10	DIN: X5CrNi18 10 ASTM: A 182 AISI 304 BS: 1449-2 304 S15
2	2	Packing	PTFE	
1	1	Corps / Body	Cast iron EN-GJL-250 (NF EN 1561)	DIN: GG25 ASTM: A48 class 40B BS: 1452 Grade 250
Pos.	Qty.	Description	Material	

\* Pre-shaped parts up to DN300.  
\*\* Missing parts on metal / metal tightness.

### DIMENSIONS

DN		A	B	C	D	E	Ø V	H	Ø K	n	Ø M	Weight (kg)
mm	inch											
400	16"	100	945	494	290	1073	500	1594	515	16	10-M24	159
450	18"	106	1040	547	290	1168	500	1708	565	20	14-M24	198
500	20"	110	1150	613	290	1278	500	1930	620	20	14-M24	233
600	24"	110	1354	716	290	1482	800	2182	725	20	14-M27	277
700	28"	110	1540	835	400	1668	800	2488	840	24	16-M27	456
800	32"	110	1750	972	400	1878	800	2818	950	24	16-M30	612
900	36"	110	1990	1041	400	2118	800	3238	1050	28	20-M30	657
1000	40"	110	2195	1152	450	2323	800	3563	1160	28	20-M33	917
1200	48"	120	2390	1255	450	2518	960	4018	1380	32	22-M36	1260

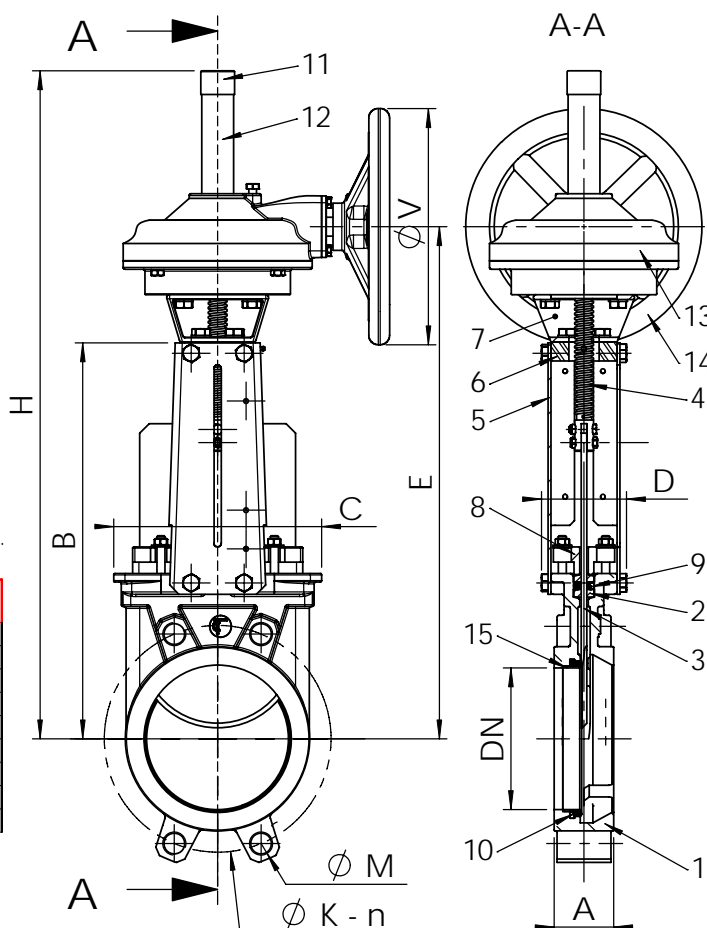

Ref. : VG 3400-08.pas

Rev. : A

Date : 03/10/08

Page : 2/2

# KNIFE GATE VALVE WITH GEAR BOX

## VG 3400-08



ISO 9001 : 2000

Certifié par



ROBINETTERIE INDUSTRIELLE ET ACCESSOIRES  
INDUSTRIAL VALVES AND ACCESSORIES

### WORKING CONDITIONS

Maximum working pressure :

DN 400-450 : 7 bar.

DN 500-600 : 4 bar.

DN 700-1200 : 2 bar.

Maximum temperature : -10°C / + 80°C.

Others materials on request (If marked)	Maximum temperature	
Metal / metal	T max : -10°C / +200°C.	<input type="checkbox"/>
White NBR	T max : -10°C / +80°C.	<input type="checkbox"/>
EPDM	T max : -20°C / +130°C.	<input type="checkbox"/>
Silicone	T max : -20°C / +170°C.	<input type="checkbox"/>
FPM (Type Viton®)	T max : -10°C / +170°C.	<input type="checkbox"/>
PTFE	T max : +4°C / +170°C.	<input type="checkbox"/>
CSM (Type Hypalon®)	T max : +4°C / +80°C.	<input type="checkbox"/>



Standard tightness



Tightness metal / metal

### STANDARDS

Manufacture according to the requirements of the European directive 97/23/CE «Equipments under pressure» : category III modulate H.

Test procedures are established according to standards EN 12266-1, DIN 3230, BS 5154 and ISO 5208.

Connections between flanges according to standard EN 1092-2 and DIN 2501 ISO PN10.