

KNIFE GATE VALVE WITH LEVER

VG 3400-02



ROBINETTERIE INDUSTRIELLE ET ACCESSOIRES
INDUSTRIAL VALVES AND ACCESSORIES

APPLICATION

General use : Pulp production, water, water treatment, waste water, chemical industry (powdery or crystallizing products), wine-producing, pulverized products (cement work, pneumatic transport, stocking).

GENERAL CHARACTERISTICS

Function ON/OFF or regulation.
Wafer threaded mounting ISO PN10.
Unidirectional tightness, direction indication thanks to the arrow on the body.
Small retention zone: the gate is guided in the body and has little clearance.
Gland assembly: packing and O-ring (same material as seat joint) to assure the elasticity and decrease the operating force.
Small head loss.
Possibility to regulate thick fluids the adaptation of a diaphragm ring .

CONSTRUCTION

13	1	Locked screw	Coated steel	
12	1	O-ring	Nitril	
11**	1	Support ring	Stainless steel 316	DIN : X5CrNiMo18 10 ASTM : A 182 AISI316 BS : 316 S16
10**	1	Gasket	Nitril	
9	1	Packing gland	Aluminium	
8	1	Lever	Steel	
7	1	Guiding ring	Bronze	
6	1	Nut support	Zinc steel	
5*	2	Support plate	Steel + epoxy	
4	1	Stem	Stainless steel 13%Cr	
3	1	Knife gate	X5CrNi 18-10	DIN : X5CrNi 18-10 ASTM : AISI 304 BS : 304 S15
2	2	Packing	PTFE	
1	1	Body	EN-GJL-250	DIN : GG 25 ASTM : A48 class 40B BS : 1452 Grade 250
Pos.	Qty.	Description	Material	

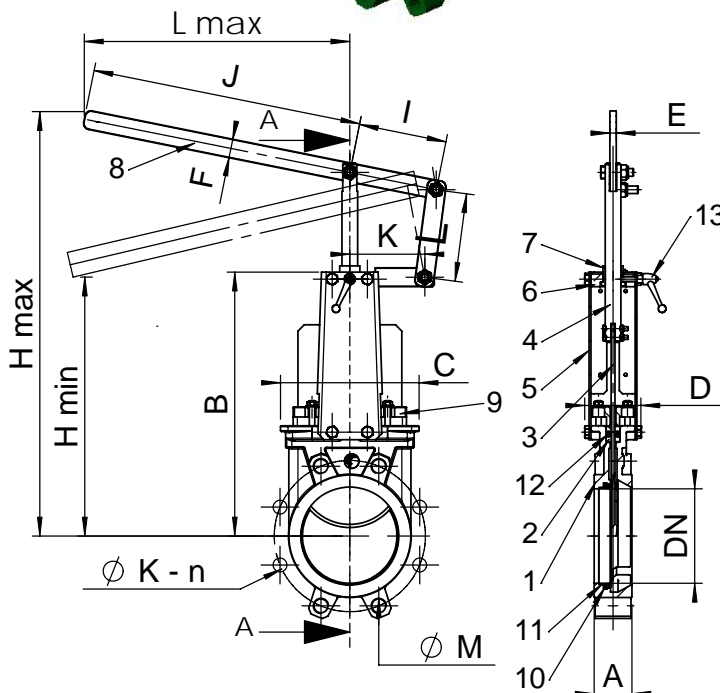

* Pre-shaped parts up to DN 300.
** Missing parts on metal-metal tightness.

DIMENSIONS

DN	mm	inch	A	B	C	D	E	F	H min	H max	L max	I	J	K	L	ØK	n	Ø M	Weight (kg)
50	50	2"	40	240	124	83	10	30	98	321	326	140	330	119	140	125	4	4-M16	7,5
65	65	2 1/2"	40	265	139	83	10	30	153	418	330	140	330	119	140	145	4	4-M16	7,8
80	80	3"	50	290	154	83	10	30	97	439	330	140	330	119	140	160	8	4-M16	8,4
100	100	4"	50	335	174	83	10	30	339	715	550	140	430	119	140	180	8	4-M16	11,5
125	125	5"	50	373	189	93	10	30	170	747	380	140	430	119	140	210	8	4-M16	14,4
150	150	6"	60	424	220	93	10	30	305	792	465	140	430	119	140	240	8	4-M20	18,5
200	200	8"	60	533	275	108	12	40	589	1202	809	228	638	173	255	295	8	4-M20	28,8
250	250	10"	70	625	326	108	12	40	538	1273	711	228	638	173	255	350	12	8-M20	41,0
300	300	12"	70	732	380	108	12	40	458	1350	702	228	638	173	255	400	12	8-M20	58,0

Ref. : VG 3400-02.pas

Rev. : A

Date : 30/09/08

Page : 2/2

KNIFE GATE VALVE WITH LEVER

VG 3400-02



ISO 9001 : 2000

Certifié par



ROBINETTERIE INDUSTRIELLE ET ACCESSOIRES
INDUSTRIAL VALVES AND ACCESSORIES

WORKING CONDITIONS

Maximum working pressure : DN 50-250 : 10 bar
DN 300 : 7 bar

Maximum temperature : -10°C / +80°C

Others materials on request (If marked)	Maximum temperature	
Metal / metal	T max : -10°C / +200°C.	<input type="checkbox"/>
White NBR	T max : -10°C / +80°C.	<input type="checkbox"/>
EPDM	T max : -20°C / +130°C.	<input type="checkbox"/>
Silicone	T max : -20°C / +170°C.	<input type="checkbox"/>
FPM (Type Viton®)	T max : -10°C / +170°C.	<input type="checkbox"/>
PTFE	T max : +4°C / +170°C.	<input type="checkbox"/>
CSM (Type Hypalon®)	T max : +4°C / +80°C.	<input type="checkbox"/>



Standard tightness



Tightness metal/metal

STANDARDS

Manufacture according to the requirements of the European directive 97/23/CE «Equipments under pressure» : category III modulate H.
On request : Product in accordance to european directive "Potentially explosive atmospheres" N° 94/9/EC : ATEX II 2 GD c and ATEX II 3 GD c.
Test procedures are established according to standard EN 12266-1, DIN 3230, BS 5154 and ISO 5208.
Connections according to standard EN 1092-2 and DIN 2501 : ISO PN10.