

Ref. : RC 3242.pas

Rev. : A

Date : 25/10/06

Page : 1/1

# FLANGED BALANCING VALVE PN16

## RC 3242



ROBINETTERIE INDUSTRIELLE ET ACCESSOIRES  
INDUSTRIAL VALVES AND ACCESSORIES

### APPLICATION

TECOFI balancing valves are used for accurate adjustment on big heating and cooling systems, in new jobs or maintenance.

### GENERAL CHARACTERISTICS

The TECOFI valves have an oblique seat which offers a good adjustment precision and a resistance lower than the valves with a straight seat: head losses are small, which for a same DN leads to more important flows than those borne by a straight seat valve.

Every RC 3242 balancing valves allows the measure of the head losses from the DN 40.

The valve opening is visualised by a small scale on the cap.

A stroke limiter on the valve cap allows the adjustment memorization.

The balancing valve can be used as a «stop valve» and allows also the fast draining and padding thanks to the drain plug.

### CONSTRUCTION

13	1	Packing	Graphite	
12	1	Gasket	Fiber	
11	1	Stop screw	Steel	
10	1	Adjusting indicator	Cast iron	
09	1	Small scale	Steel	
08	2	Pressure test point	Brass	
07	1	Valve	Stainless steel 304 GX5CrNi 19-10	DIN: G-X6CrNi18 9 ASTM: A 351 CF8 BS: 1504 304 C15
06	1	Seat	Stainless steel	
05	1	Stem	Stainless steel 304 X5CrNi 18-10	DIN: X5CrNi18 10 ASTM: A 182 AISI 304 BS: 1449-2 304 S15
04	1	Handwheel	Steel	
03	1	Packing gland	Cast iron	
02	1	Bonnet	Cast iron EN-GJL-250	DIN: GG25 ASTM: A48 class 40B BS: 1452 Grade 250
01	1	Body	Cast iron EN-GJL-250	DIN: GG25 ASTM: A48 class 40B BS: 1452 Grade 250
Pos.	Qty.	Description	Material	

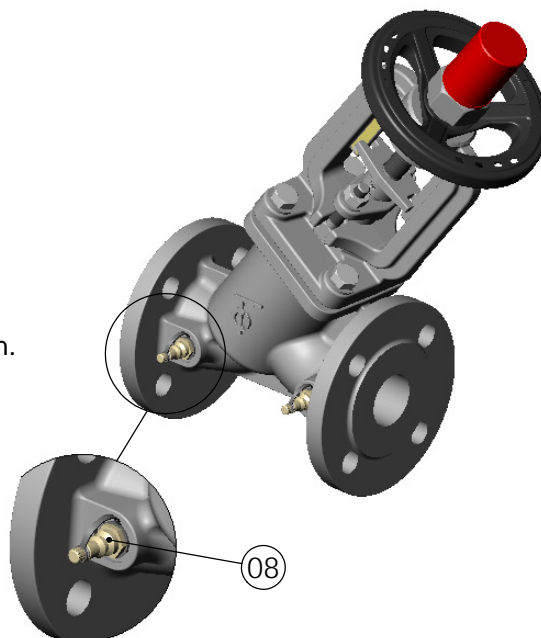

### DIMENSIONS

DN		L	H	Kvs (m <sup>3</sup> /h)	Weight (kg)
mm	inch				
40	1" 1/2	200	330	36,88	12,5
50	2"	230	335	58,42	15,2
65	2" 1/2	290	360	96,90	23,0
80	3"	310	420	145,0	29,0
100	4"	350	425	232,4	40,5
125	5"	400	465	370,8	56,0
150	6"	480	500	500,6	75,5
200	8"	600	665	910,1	136,5
250	10"	730	795	1302,0	210,0
300	12"	850	880	1680,0	270,0

### WORKING CONDITIONS

PS max : 16 bar (TS max : +120 °C)  
 14,4 bar (TS max : +150 °C)  
 13,4 bar (TS max : +180 °C)  
 12,8 bar (TS max : +200 °C)  
 11,8 bar (TS max : +230 °C)  
 11,2 bar (TS max : +250 °C)  
 9,6 bar (TS max : +300 °C)

Pressure test according to standards  
 EN 12266-1, DIN 3230, BS 6755 and ISO 5208.

### STANDARDS

Flanges DN drilled according to EN 1092-2 ISO PN16. E-mail : tecofi@tecofi.fr - Service commercial / Sales dep. : sales@tecofi.fr - www.tecofi.fr

