

Ref. : VG 3400-BX4.pas

Rev. : Initial

Date : 02/03/09

Page : 1/2

KNIFE GATE VALVE WITH ELECTRIC ACTUATOR "BERNARD"

VG 3400-BX4



ROBINETTERIE INDUSTRIELLE ET ACCESSOIRES
INDUSTRIAL VALVES AND ACCESSORIES

PRODUCT REFERENCE

	REFERENCES	Electric actuator type
<input type="checkbox"/>	VG 3400-B04	BERNARD 400V 3 PH
<input type="checkbox"/>	VG 3400-B14	BERNARD 230V 3 PH
<input type="checkbox"/>	VG 3400-B24	BERNARD 230V 1 PH
<input type="checkbox"/>

APPLICATION

General use : Pulp production, water, water treatment, waste water, chemical industry (powdery or crystallizing products), wine-producing, pulverized products (cement work, pneumatic transport, stocking).

GENERAL CHARACTERISTICS

Function ON/OFF or regulation.
Wafer threaded mounting ISO PN10.
Unidirectional tightness, direction indication thanks to the arrow on the body.
Small retention zone: the gate is guided in the body and has little clearance.
Gland assembly: packing and O-ring (same material as seat joint) to assure the elasticity and decrease the operating torque.
Small head loss.
Possibility to regulate thick fluids the adaptation of a diaphragm ring .

CONSTRUCTION

11	1	Electric actuator		BERNARD
10**	1	Support ring	Stainless steel 316	DIN : X5CrNiMo18 10 ASTM : A 182 AIS 3 16 BS : 316 S16
9**	1	Gasket	Nitril	
8	1	O-ring	Nitril	
7	1	Packing gland	Aluminium (DN50-450) Acier (DN500-600)	
6	1	Nut support	Painted steel	
5*	2	Support plate	Steel + epoxy	
4	1	Stem	Stainless steel 13%Cr	
3	1	Knife gate	X5CrNi 18-10	DIN : X5CrNi 18-10 ASTM : AISI 304 BS : 304 S15
2	2	Packing	PTFE	
1	1	Body	EN-GJL-250	DIN : GG 25 ASTM : A48 class 40B BS : 1452 Grade 250
Pos.	Qty.	Description	Material	

* Pre-shaped parts up to DN 300.

**Missing parts on metal/metal tightness.

DIMENSIONS

DN	Actuator type	A	B	C	D	E	F	Ø V	H	Ø K	n	Ø M	Weight (kg)	
mm	inch													
50	2"	SRA6	40	584	124	83	291	247	300	584	125	4	4-M16	28
65	2 1/2"	SRA6	40	609	139	83	291	247	300	609	145	4	4-M16	30
80	3"	SRA6	50	634	154	83	291	247	300	634	160	8	4-M16	31
100	4"	SRA6	50	679	174	83	291	247	300	679	180	8	4-M16	32
125	5"	SRA6	50	717	189	93	291	247	300	717	210	8	4-M16	37
150	6"	SRA6	60	768	220	93	291	247	300	768	240	8	4-M20	41
200	8"	SRA6	60	887	275	108	291	247	300	887	295	8	4-M20	58
250	10"	SRA6	70	979	326	108	291	247	300	998	350	12	8-M20	72
300	12"	ST14	70	1110	380	108	265	318	300	1157	400	12	8-M20	83
350	14"	ST14	96	1220	438	290	265	318	300	1305	460	16	10-M20	135
400	16"	ST14	100	1330	494	290	265	318	300	1473	515	16	10-M24	165
450	18"	ST30	106	1475	547	290	310	433	450	1628	565	20	14-M24	206
500	20"	ST30	110	1585	613	290	310	433	450	1778	620	20	14-M24	241
600	24"	ST30	110	1789	716	290	310	433	450	2079	725	20	14-M27	296

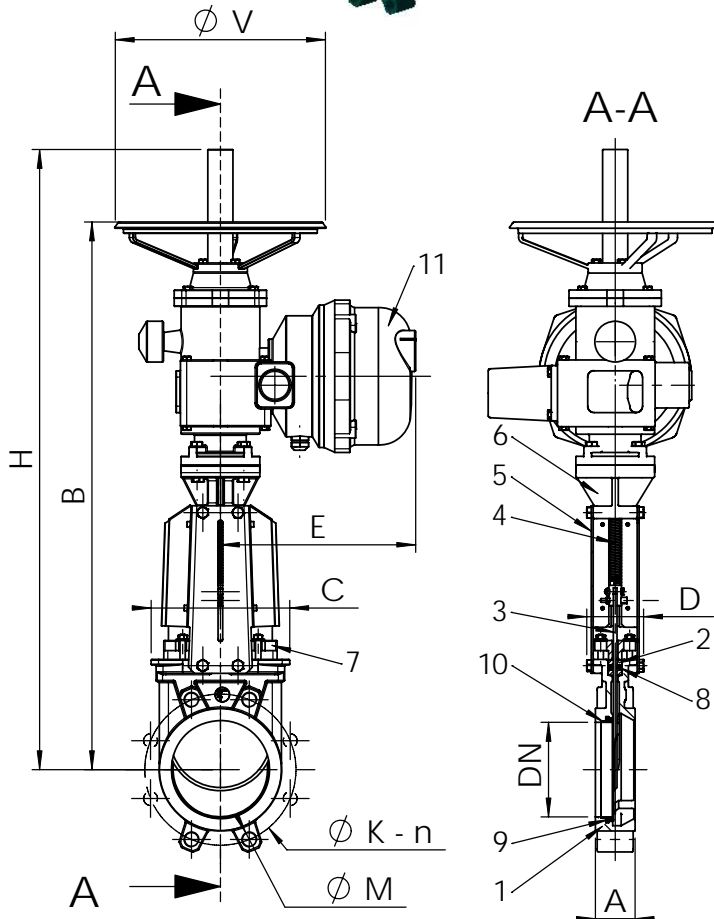

Ref. : VG 3400-BX4.pas

Rev. : Initial

Date : 02/03/09

Page : 2/2

KNIFE GATE VALVE WITH ELECTRIC ACTUATOR "BERNARD"

VG 3400-BX4



ISO 9001 : 2000

Certifié par



ROBINETTERIE INDUSTRIELLE ET ACCESSOIRES
INDUSTRIAL VALVES AND ACCESSORIES

WORKING CONDITIONS

Maximum working pressure : DN 50-250 : 10 bar
DN 300-450 : 7 bar
DN 500-600 : 4 bar

Maximum temperature : -10°C / +80°C (Standard tightness)

Others material on request (If marked)	Maximum temperature	
Metal / metal	T max : -10°C / +200°C.	<input type="checkbox"/>
White Nitril	T max : -10°C / +80°C.	<input type="checkbox"/>
EPDM	T max : -20°C / +130°C.	<input type="checkbox"/>
Silicone	T max : -20°C / +170°C.	<input type="checkbox"/>
FPM (Type Viton®)	T max : -10°C / +170°C.	<input type="checkbox"/>
PTFE	T max : +4°C / +170°C.	<input type="checkbox"/>
CSM (Type Hypalon®)	T max : +4°C / +80°C.	<input type="checkbox"/>



Standard tightness



Tightness metal/metal

STANDARDS

Manufacture according to the requirements of the European directive 97/23/CE «Equipments under pressure» : fluids category III modulate H.

Test procedures are established according to standard EN 12266-1, DIN 3230, BS 5154 and ISO 5208.

Connections according to standard EN 1092-2 and DIN 2501 : ISO PN10.