

Ref. : VP 3648-04.pas

Rev. : Initial

Date : 07/06/07

Page : 1/1

THREADED LUGS BUTTERFLY VALVE WITH ELECTRIC ACTUATOR

VP 3648-04



ROBINETTERIE INDUSTRIELLE ET ACCESSOIRES
INDUSTRIAL VALVES AND ACCESSORIES

APPLICATION

General use : Water, air, acids etc.

GENERAL CHARACTERISTICS

Design in accordance with NF EN 593.
TECFLY LUG: type with threaded lugs allowing screw assembling.
Tightness in both ways.
Two kinds of sleeves:
- Body in dovetail shape ensures a perfect assembling (for high vacuum we can stick it)
- Internally reinforced resin sleeve giving a lower torque
Stem: high and low semi stem giving a high flow coefficient.
Machined disc with on periphery giving a low and regular torque.
Stem unjectable, bearing: stainless steel teflon lined.
Dovetail type sleeve, accordind to ISO 5211.

CONSTRUCTION

12	4	Screw	Stainless steel	
11	4	Washer	Stainless steel	
10	1	Electric actuator	Aluminium	
9	2	Split pin	Stainless steel	
8	1	Gasket	NBR	
7	2	O-Ring	NBR	
6	2	Guiding bearing	Teflond-lined	
5	1	Upper stem	Stainless steel 416	DIN : 1.4005 ASTM : AISI 416 BS : 416 S 21
4	1	Lower stem	Stainless steel 416	DIN : 1.4005 ASTM : AISI 416 BS : 416 S 21
3	1	Sleeve	Heat EPDM	Standard
2	1	Disc	EN-GJS-400-15	DIN : GGG 40 ASTM : A 536 65-45-12 BS : EN-JS1030
1	1	Body	Cast iron EN-GJL-250	DIN : GG25 ASTM : A48 class 40B BS : 1452 Grade 250
Pos.	Qty.	Description	Material	

DIMENSIONS

DN	Electric actuator	G	H1	L	X	V	V1	W1	ØP	Type	Weight (kg)
40 - 1" 1/2	Mono / 1 ph OA3	66	134	33	224	264	148	190	90	F07	9,2
	Tri / 3 ph OA6					376	260				
50 - 2"	Mono / 1 ph OA3	72	140	43	224	264	148	190	90	F07	9,8
	Tri / 3 ph OA6					376	260				
65 - 2" 1/2	Mono / 1 ph OA3	78	153	46	224	264	148	190	90	F07	10,8
	Tri / 3 ph OA6					376	260				
80 - 3"	Mono / 1 ph OA3	89	159	46	224	264	148	190	90	F07	11,8
	Tri / 3 ph OA6					376	260				
100 - 4"	Mono (or) Tri OA6	102	178	52	224	376	260	190	90	F07	13,3
125 - 5"	Mono (or) Tri OA8	117	190	56	224	376	260	190	90	F07	16,6
150 - 6"	Mono (or) Tri OA15	130	203	56	224	376	260	190	90	F07	18,9
200 - 8"	Mono (or) Tri AS18	159	238	60	177	479	312	315	100	F10	34,6
250 - 10"	Mono (or) Tri AS50	190	268	68	177	509	340	315	250	F10	47,7
300 - 12"	Mono (or) Tri AS50	222	306	78	177	509	340	315	250	F10	60,0

WORKING CONDITIONS

Maximun working pressure : 16 bar.

Maximun temperature : -15°C / +130°C.

Peak temperature : -30°C / +150°C.

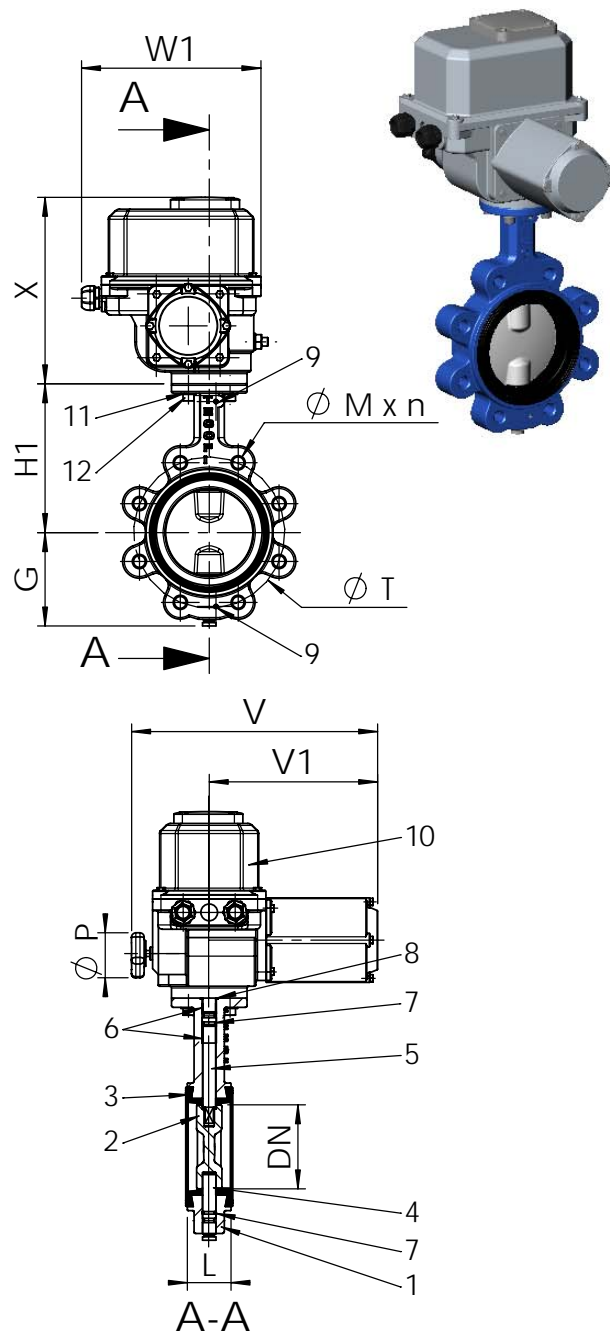

STANDARDS

Manufacture according to the requirements of the European directive 97/23/CE «Equipments under pressure» : fluids category III modulate H.
Pressure test according to standards EN 12266-1, DIN 3230, BS 6755 and ISO 5208 :
Body : 24 bar.
Seat : 17,6 bar.

Face to face according to standard NF EN 558-1 serie 20, ISO 5752 serie 20, DIN 3202.

Mounting between flanges PN10 / PN16 up to DN150 and PN10 for upper diameters: according to EN 1092-2, BS450, ANSI B16.1-5.
Adjustable between flanges PN16 and ASA 150 on request.