

Ref. : VP 3648-08.pas

Rev. : Initial

Date : 08/06/07

Page : 1/1

# THREADED LUGS BUTTERFLY VALVE WITH GEAR BOX

## VP 3648-08



ROBINETTERIE INDUSTRIELLE ET ACCESSOIRES  
INDUSTRIAL VALVES AND ACCESSORIES

### APPLICATION

General use : Water, air, acids etc.

### GENERAL CHARACTERISTICS

Design in accordance with NF EN 593.  
TECFLY LUG: type with threaded lugs allowing screw assembling.  
Tightness in both ways.  
Two kinds of sleeves:  
- Body in dovetail shape ensures a perfect assembling (for high vacuum we can stick it)  
- Internally reinforced resin sleeve giving a lower torque  
Stem: high and low semi stem giving a high flow coefficient.  
Machined disc with on periphery giving a low and regular torque.  
Stem unjectable, bearing: stainless steel teflon lined.  
Dovetail type sleeve, accordind to ISO 5211.



### CONSTRUCTION

12	4	Screw	Stainless steel	
11	4	Washer	Stainless steel	
10	1	Gear box	Cast iron	
9	2	Split pin	Stainless steel	
8	1	Gasket	NBR	
7	2	O-Ring	NBR	
6	2	Guiding bearing	Teflon-lined	
5	1	Upper stem	Stainless steel 416	DIN : 1.4005 ASTM : AISI 416 BS : 416 S 21
4	1	Lower stem	Stainless steel 416	DIN : 1.4005 ASTM : AISI 416 BS : 416 S 21
3	1	Sleeve	Heat EPDM	Standard
2	1	Disc	EN-GJS-400-15	DIN : GGG 40 ASTM : A 536 65-45-12 BS : EN-JS1030
1	1	Body	Cast iron EN-GJL-250	DIN : GG25 ASTM : A48 class 40B BS : 1452 Grade 250
Pos.	Qty.	Description	Material	

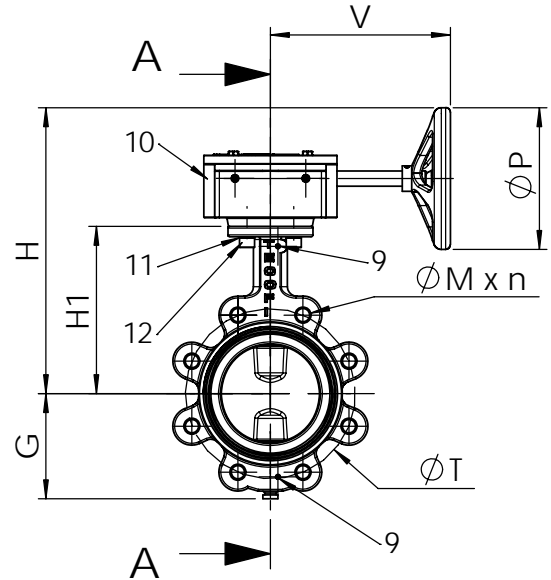

### DIMENSIONS

DN	ISO PN	H	H1	L	Ø T	n	Ø M	V	P	G	TYPE	Weight (kg)
DN 40 – 1" 1/2	10 / 16	248	133	33	110	4	M 16	148	150	66	F07	8
DN 50 – 2"	10 / 16	255	140	43	125	4	M 16	148	150	71	F07	8.9
DN 65 – 2" 1/2	10 / 16	268	153	46	145	4	M 16	148	150	78	F07	9.9
DN 80 – 3"	10 / 16	274	159	46	160	8	M 16	148	150	89	F07	10.9
DN 100 – 4"	10 / 16	293	178	52	180	8	M 16	148	150	102	F07	12.3
DN 125 – 5"	10 / 16	305	190	56	210	8	M 16	148	300	117	F07	14.6
DN 150 – 6"	10 / 16	318	203	56	240	8	M 20	148	300	130	F07	16.9
DN 200 – 8"	10	430	238	60	295	8	M 20	238	300	159	F10	29.9
DN 250 – 10"	10	460	268	68	350	12	M 20	238	300	190	F10	43.6
DN 300 – 12"	10	495	306	78	400	12	M 20	226	300	222	F10	56

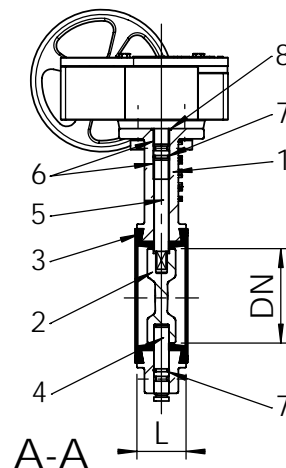

### STANDARDS

Manufacture according to the requirements of the European directive 97/23/CE «Equipments under pressure» : fluids category III modulate H.

Pressure test according to standards EN 12266-1, DIN 3230, BS 6755 and ISO 5208 :

Body : 24 bar.  
Seat : 17,6 bar.

Face to face according to standard NF EN 558-1 serie 20, ISO 5752 serie 20, DIN 3202.

Mounting between flanges PN10 / PN16 up to DN150 and PN10 for upper diameters: according to EN 1092-2, BS450, ANSI B16.1-5.

Adjustable between flanges PN16 and ASA 150 on request.

### WORKING CONDITIONS

Maximun working pressure : 16 bar.  
Maximun temperature : -15°C / +130°C.  
Peak temperature : -30°C / +150°C.

5, impasse Pascal - Z.I. - BP 177 - 69686 CHASSIEU Cedex - FRANCE  
Tél. +33 (0) 4 72 79 05 79 - Fax +33 (0) 4 78 90 19 19 / +33 (0) 4 72 79 05 70  
E-mail : tecofi@tecofi.fr - Service commercial / Sales dep. : sales@tecofi.fr - www.tecofi.fr