

FLANGE DIAPHRAGM VALVE NON RISING STEM CURVED WAY TYPE

RMC 3200-000



ROBINETTERIE INDUSTRIELLE ET ACCESSOIRES
INDUSTRIAL VALVES AND ACCESSORIES

PRODUCT REFERENCE

REFERENCES	Type
<input type="checkbox"/> RMC3200-000	Body lining ebonite
<input type="checkbox"/> RMC3200F-000	Cast iron body

APPLICATION

General use : water treatment plants, fertilizer & petrochemicals industries, chemical industries, refineries, thermal power stations, etc

GENERAL CHARACTERISTICS

Design in accordance EN 13397.
Range : from DN15 to DN350
Curved way type.
Low head loss.
Diaphragm replaceable without removing the valve.

CONSTRUCTION

9	Handwheel	Cast iron	
8	Lubricator		for DN125 and above
7	Bonnet	Cast iron	
6	Thrust bearing		for DN80 and above
5	Stem bush	Cast iron GS	
4	Stem	Stainless steel 410	
3	Compressor	Cast iron	
2	Diaphragm	See table*	Standard = Butyl
1	Body	Cast iron or cast iron lining ebonite	
Pos.	Description	Material	

DIMENSIONS

DN		A	B	Ø C	Ø D	Ø K	n x Ø M	Weight (kg)		
mm	inch							BS	DIN	MSS
15	1/2"	108	92	70	95	65	4 x 14	2.5	2.8	2.5
20	3/4"	117	100	70	105	75	4 x 14	2.6	3.2	3.0
25	1"	127	114	100	115	85	4 x 14	3.5	4.2	4.0
32	1 1/4"	146	115	100	140	100	4 x 18	4.5	5.5	5.0
40	1 1/2"	159	153	140	150	110	4 x 18	7.0	8.0	7.5
50	2"	190	160	140	165	125	4 x 18	10	15	11
65	2 1/2"	216	180	180	185	145	4 x 18	15	19	16
80	3"	254	233	225	200	160	8 x 18	22	26	23
100	4"	305	256	225	220	180	8 x 18	37	42	37
125	5"	356	306	310	250	210	8 x 18	62	68	70
150	6"	406	368	368	285	240	8 x 22	91	106	93
200	8"	521	479	471	340	295	8 x 22	163	185	166
250	10"	635	585	587	395	350	12 x 22	240	275	-
300	12"	749	689	690	445	400	12 x 22	418	480	-
350	14"	749	830	690	505	460	16 x 22	480	550	-

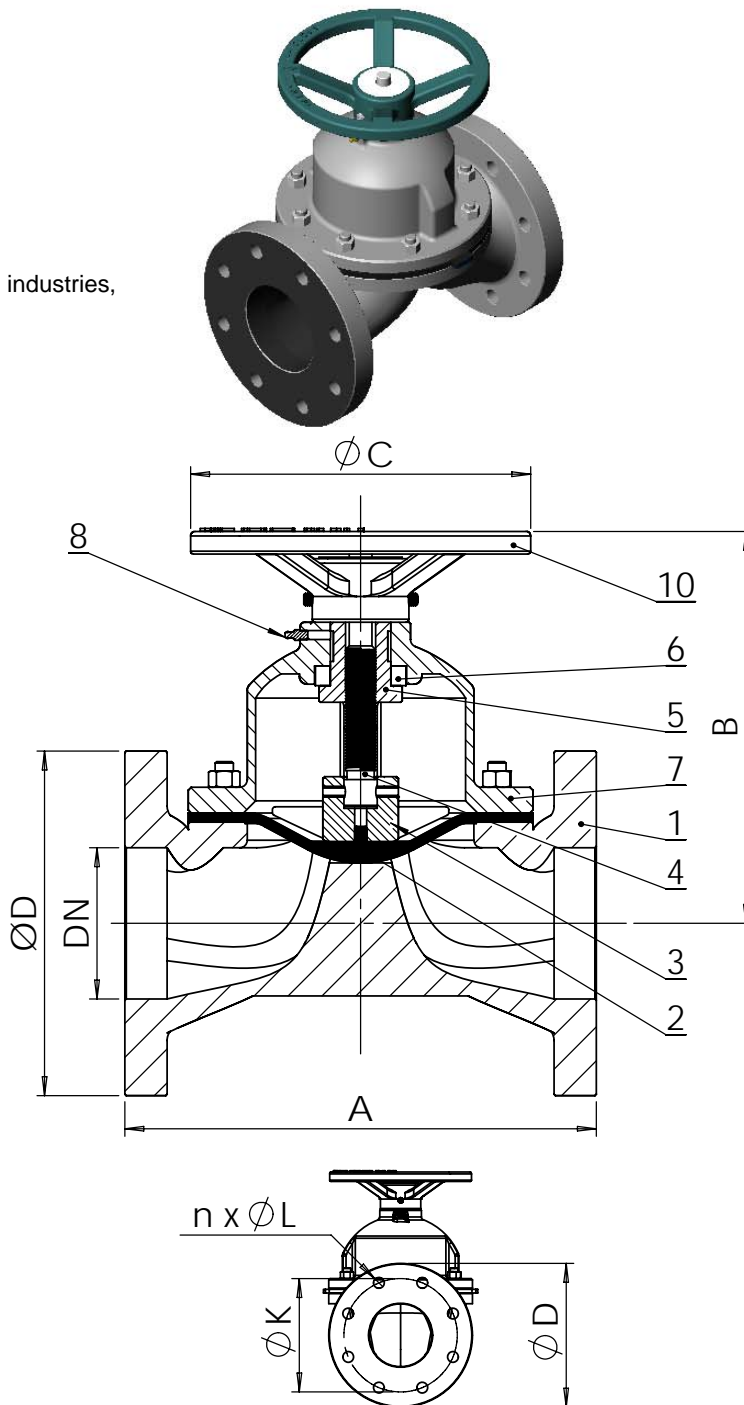

WORKING CONDITIONS

Maximum working pressure : DN15 with 50 = 16 bar.
DN65 with 150 = 10 bar.
DN200 = 7 bar.
DN250 with 350 = 6 bar.

STANDARDS

Pressure test according to standard EN12266-41, BS 6755-1:

Body : 1.5 x PS bar.
Seat : 1.1 x PS bar.

Face to face according to EN 558-1.
Connection according to standard EN 1092-2 ISO PN10/16/40 (DN15-40), PN10/16 (DN50-150), PN10 (DN200-350).

*on request ASME / BS / DIN / JIS.

Ref.	Diaphragm materials	Application	Hardness	UTS (kg/cm²)	Temp.
BU	IIR (Type Butyl®)	Steam sterilisation	60 - 70	100	-25°C / 120°C
AL	White IIR (Type Butyl®)	Food and pharmaceuticals	55- 65	80	-25°C / 105°C
EP	Ethylene propylene	Radio active materials	65 -75	890	-30°C / 150°C
CN	Natural rubber	Mildly acid resistant	65 -75	170	-30°C / 80°C
NE	CR (Type neoprene®)	Diluted acid resistant	60 - 70	120	-25°C / 95°C
HY	CSM (Type Hypalon®)	Acid resistant	60 - 70	80	-15°C / 100°C
VI	FPM (Type Viton®)	Aromatics chlorine	70 - 80	70	-5°C / 150°C
PF	PTFE	All chemicals and food application	-	70	-30°C / 175°C
SI	Silicone Rubber	High temperatures resistance	55 -65	70	-100°C / 250°C
NI	Nitrile rubber (BUNA-N)	Oils and fats	65 - 75	120	-10°C / 90°C