

Ref. : VG 3400-05.pas

Rev. : Initial

Date : 01/10/08

Page : 1/2

KNIFE GATE VALVE WITH SQUARE DRIVING RISING STEM

VG 3400-05



ROBINETTERIE INDUSTRIELLE ET ACCESSOIRES
INDUSTRIAL VALVES AND ACCESSORIES

APPLICATION

General use : Pulp production, water, water treatment, waste water, chemical industry (powdery or crystallizing products), wine-producing, pulverized products (cement work, pneumatic transport, stocking).

GENERAL CHARACTERISTICS

Function ON/OFF or regulation.
Wafer threaded mounting ISO PN10.
Unidirectional tightness, direction indication thanks to the arrow on the body.
Small retention zone: the gate is guided in the body and has little clearance.
Gland assembly: packing and O-ring (same material as seat joint) to assure the elasticity and decrease the operating torque.
Small head loss.
Possibility to regulate thick fluids the adaptation of a diaphragm ring .



CONSTRUCTION

17**	1	Support ring	Stainless steel 316	DIN: X5CrNiMo 18 10 ASTM: A 182 AISI 316 BS: 970 316 S16
16	1	Greaser	Stainless steel	
15	1	Stop srew	Stainless steel	
14	1	Friction washer	Bronze	
13	1	Check nut	Cast iron EN-GJL-250	DIN: GG25 ASTM: A48 class 40B BS: 1542 Grade 250
12	1	Protection tube	Steel	
11	1	Driving square	Cast iron EN-GJL-250	DIN: GG25 ASTM: A48 class 40B BS: 1542 Grade 250
10**	1	Gasket	Nitril	
9	1	O-ring	Nitril	
8	1	Packing gland	Aluminium	
7	1	Nut	Bronze	
6	1	Nut potence	Zinc steel	
5*	2	Support plate	Steel + epoxy	
4	1	Stem	Stainless steel 13%Cr	
3	1	Knife gate	Stainless steel X5CrNi 18-10	DIN: X5CrNi 18 10 ASTM: A 182 AISI 304 BS: 1449-2 304 S15
2	2	Packing	PTFE	
1	1	Body	Cast iron EN-GJL-250	DIN: GG25 ASTM: A48 class 40B BS: 1542 Grade 250
Pos.	Qty.	Description	Material	

* Pre-shaped parts up to DN300.
** Missing parts on metal / metal tightness.

DIMENSIONS

Ø DN		A	B	C	D	H	Ø K	n	Ø M	Weight (Kg)
mm	inch									
50	2"	40	240	124	83	475	125	4	4-M16	6,5
65	2 1/2"	40	265	139	83	500	145	4	4-M16	7,8
80	3"	50	290	154	83	530	160	8	4-M16	8,4
100	4"	50	335	174	83	570	180	8	4-M16	10,5
125	5"	50	373	189	93	650	210	8	4-M16	14,4
150	6"	60	424	220	93	700	240	8	4-M20	17,5
200	8"	60	533	275	108	870	295	8	4-M20	32,8
250	10"	70	625	326	108	1070	350	12	8-M20	45,0
300	12"	70	732	380	108	1170	400	12	8-M20	59,0
350	14"	96	835	438	290	1430	460	16	10-M20	114,0
400	16"	100	945	494	290	1520	515	16	10-M24	148,0

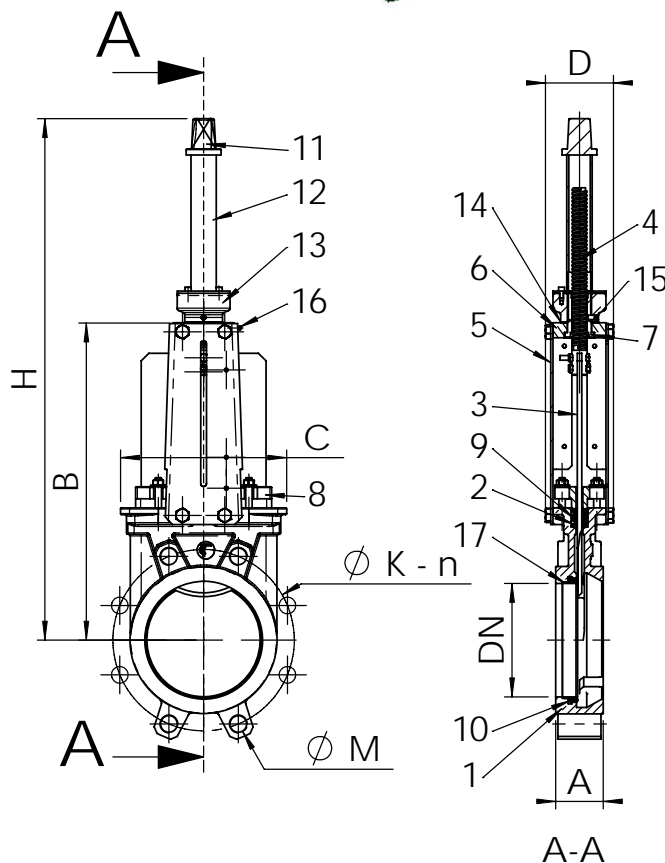

Ref. : VG 3400-05.pas

Rev. : Initial

Date : 01/10/08

Page : 2/2

KNIFE GATE VALVE WITH SQUARE DRIVING RISING STEM

VG 3400-05



ROBINETTERIE INDUSTRIELLE ET ACCESSOIRES
INDUSTRIAL VALVES AND ACCESSORIES

WORKING CONDITIONS

Maximum working pressure : DN 50-250 : 10 bar
DN 300-400 : 7 bar

Maximum temperature : -10°C / +80°C

Others materials on request (If marked)	Maximum temperature	
Metal / metal	T max : -10°C / +200°C.	<input type="checkbox"/>
White NBR	T max : -10°C / +80°C.	<input type="checkbox"/>
EPDM	T max : -20°C / +130°C.	<input type="checkbox"/>
Silicone	T max : -20°C / +170°C.	<input type="checkbox"/>
FPM (Type Viton®)	T max : -10°C / +170°C.	<input type="checkbox"/>
PTFE	T max : +4°C / +170°C.	<input type="checkbox"/>
CSM (Type Hypalon®)	T max : +4°C / +80°C.	<input type="checkbox"/>



Standard tightness



Tightness metal/metal

STANDARDS

Manufacture according to the requirements of the European directive 97/23/CE «Equipments under pressure» : category III modulate H.
On request : Product in accordance to european directive "Potentially explosive atmospheres" N° 94/9/EC : ATEX II 2 GD c and ATEX II 3 GD c.
Test procedures are established according to standard EN 12266-1, DIN 3230, BS 5154 and ISO 5208.
Connections according to standard EN 1092-2 and DIN 2501 : ISO PN10.