

Ref. : VG 3400-051.pas

Rev. : A

Date : 01/10/08

Page : 1/2

# KNIFE GATE VALVE WITH SQUARE DRIVING NONE RISING STEM

## VG 3400-051



ROBINETTERIE INDUSTRIELLE ET ACCESSOIRES  
INDUSTRIAL VALVES AND ACCESSORIES

### APPLICATION

General use : Pulp production, water, water treatment, waste water, chemical industry (powdery or crystallizing products), wine-producing, pulverized products (cement work, pneumatic transport, stocking).

### GENERAL CHARACTERISTICS

Function ON/OFF or regulation.  
Wafer threaded mounting ISO PN10.  
Unidirectional tightness, direction indication thanks to the arrow on the body.  
Small retention zone: the gate is guided in the body and has little clearance.  
Gland assembly: packing and O-ring (same material as seat joint) to assure the elasticity and decrease the operating torque.  
Small head loss.  
Possibility to regulate thick fluids the adaptation of a diaphragm ring .



### CONSTRUCTION

14	1	Support ring	Stainless steel 316	DIN : X5CrNiMo18 10 ASTM : A 182 AIS 3 16 BS : 316 S16
13	1	Spring pin	Stainless steel	
12	1	Friction washer	Bronze	
11	1	Square driving	EN-GJL-250	DIN : GG 25 ASTM : A48 class 40B BS : 1452 Grade 250
10	1	Gasket	Nitril	
9	1	O-ring	Nitril	
8	1	Packing gland	Aluminium	
7	1	Nut	Bronze	
6	1	Nut support	Zinc steel	
5*	2	Support plate	Steel + epoxy	
4	1	Stem	Stainless steel 13%Cr	
3	1	Knife gate	X5CrNi 18-10	DIN : X5CrNi 18-10 ASTM : AISI 304 BS : 304 S15
2	2	Packing	PTFE	
1	1	Body	EN-GJL-250	DIN : GG 25 ASTM : A48 class 40B BS : 1452 Grade 250
<b>Pos.</b>	<b>Qty.</b>	<b>Description</b>	<b>Material</b>	

\* Pre-shaped parts up to DN 300.  
\*\* Missing parts on metal / metal tightness.

### DIMENSIONS

DN		A	B	C	D	H	Ø K	n	Ø M	Weight (kg)
mm	inch									
50	2"	40	240	124	83	327	125	4	4-M16	7,5
65	2"1/2	40	265	139	83	352	145	4	4-M16	8,8
80	3"	50	290	154	83	377	160	8	4-M16	9,4
100	4"	50	335	174	83	422	180	8	4-M16	11,5
125	5"	50	373	189	93	463	210	8	4-M16	15,4
150	6"	60	424	220	93	514	240	8	4-M20	18,5
200	8"	60	533	275	108	628	295	8	4-M20	34,8
250	10"	70	625	326	108	720	350	12	8-M20	47
300	12"	70	732	380	108	827	400	12	8-M20	61
350	14"	96	835	438	290	941	460	16	10-M20	117
400	16"	100	913	494	290	1051	515	16	10-M24	151

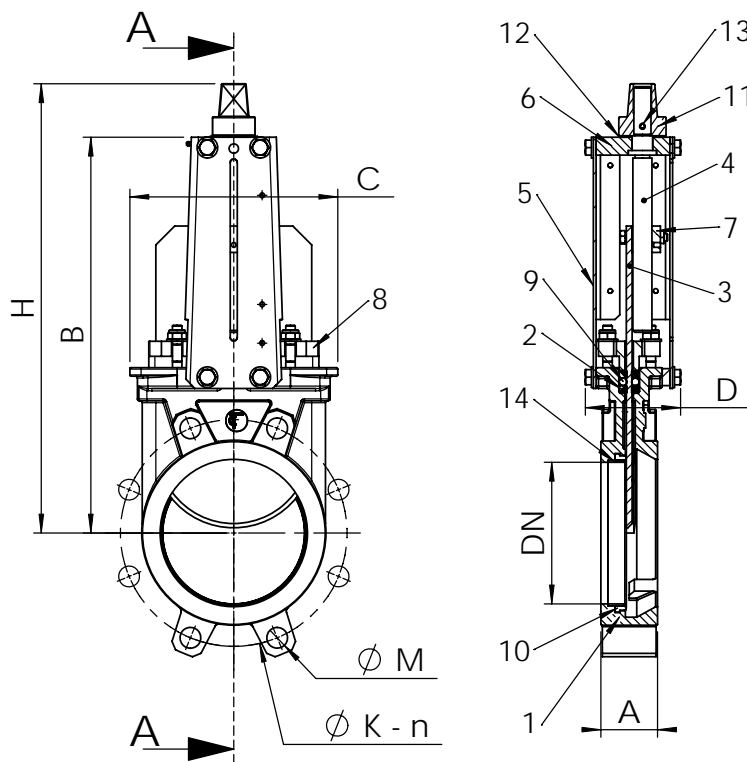

Ref. : VG 3400-051.pas

Rev. : A

Date : 01/10/08

Page : 2/2

# KNIFE GATE VALVE WITH SQUARE DRIVING NONE RISING STEM

## VG 3400-051



ISO 9001 : 2000

Certifié par



ROBINETTERIE INDUSTRIELLE ET ACCESSOIRES  
INDUSTRIAL VALVES AND ACCESSORIES

### WORKING CONDITIONS

Maximum working pressure : DN 50-250 : 10 bar  
DN 300-400 : 7 bar

Maximum temperature : -10°C / +80°C

Others materials on request (if marked)	Maximum temperature	
Metal / metal	T max : -10°C / +200°C.	<input type="checkbox"/>
White NBR	T max : -10°C / +80°C.	<input type="checkbox"/>
EPDM	T max : -20°C / +130°C.	<input type="checkbox"/>
Silicone	T max : -20°C / +170°C.	<input type="checkbox"/>
FPM (Type Viton®)	T max : -10°C / +170°C.	<input type="checkbox"/>
PTFE	T max : +4°C / +170°C.	<input type="checkbox"/>
CSM (Type Hypalon®)	T max : +4°C / +80°C.	<input type="checkbox"/>



Standard tightness



Tightness metal/metal

### STANDARDS

Manufacture according to the requirements of the European directive 97/23/CE «Equipments under pressure» : category III modulate H.

On request : Product in accordance to european directive "Potentially explosive atmospheres" N° 94/9/EC : ATEX II 2 GD c and ATEX II 3 GD c.

Test procedures are established according to standard EN 12266-1, DIN 3230, BS 5154 and ISO 5208.

Connections according to standard EN 1092-2 and DIN 2501 : ISO PN10.