

Ref. : VP 3449-03.pas

Rev. : A

Date : 26/06/08

Page : 1/1

BUTTERFLY VALVE WITH DOUBLE ACTING PNEUMATIC ACTUATOR

VP 3449-03



ROBINETTERIE INDUSTRIELLE ET ACCESSOIRES
INDUSTRIAL VALVES AND ACCESSORIES

APPLICATION

General use : Water, air, acids etc.

GENERAL CHARACTERISTICS

Design in accordance with NF EN 593.
TECFLY type with lugs enabling use on bottom line.
Tightness in both ways.
Sleeve body in dovetail shape ensures a perfect assembling (for high vacuum we can stick it)
Stem: high and low semi stem giving a high flow coefficient.
Machined disc with on periphery giving a low and regular torque.
Stem unjectable, bearing:stainless steel teflon lined.
Dovetail type sleeve, accordind to ISO 5211.

CONSTRUCTION

13	1	Spacer	Aluminium	
12	4	Screw	Stainless steel	
11	4	Washer	Stainless steel	
10	1	Double acting pneumatic actuator	Anodized aluminium	
9	2	Split pin	Stainless steel	
8	1	Gasket	NBR	
7	2	O-Ring	NBR	
6	2	Guiding bearing	Teflon-lined	
5	1	Upper stem	Stainless steel 420	DIN : 1.4021 ASTM : AISI 420 BS : 420 S 37
4	1	Lower stem	Stainless steel 420	DIN : 1.4021 ASTM : AISI 420 BS : 420 S 37
3	1	Sleeve	Heat EPDM	Standard
2	1	Disc	GX5CrNiMo 19-11-2	DIN : G-X6CrNiMo18 10 ASTM : A 351 Grade CF8M BS : 1504 316 C16
1	1	Body	Cast iron EN-GJL-250	DIN : GG25 ASTM : A48 class 40B BS : 1452 Grade 250
Pos.	Qty.	Description	Material	

DIMENSIONS

DN	REF *	H	H1	L	G	V	W1	X	TYPE	Weight (kg)
40 - 1 1/2"	DA. 63	250,5	133	33	66	162	80,5	100,5	F07	3,9
50 - 2"		257,5	140	43	71	162	80,5	100,5	F07	4,4
65 - 2 1/2"		270,5	153	46	78	162	80,5	100,5	F07	5,2
80 - 3"		276,5	159	46	89	162	80,5	100,5	F07	5,7
100 - 4"	DA. 75	312,0	178	52	102	207	97,5	117,0	F07	8,0
125 - 5"	DA. 85	335,5	190	56	117	237,5	106	128,5	F07	10,9
150 - 6"	DA. 100	361,5	203	56	130	271,5	123	141,5	F07	14,0
200 - 8"	DA. 115	431,5	238	60	159	328	137	171,5	F10	23,0
250 - 10"	DA. 125	465,5	268	68	190	366	148	183,5	F10	32,4
300 - 12"	DA. 160	540,0	306	78	222	522	187	218,0	F10	49,9

* Data sheet is according to ΔP 10 bar maxi for air pressure of 6 bar.
(For ΔP 16 bar please contact us)

WORKING CONDITIONS

Maximum working pressure : 16 bar.
Maximum temperature : -15°C / +130°C.
Peak temperature : -30°C / +150°C.

Tightness in option	Maximum temperature	Peak temperature
EPDM	+4°C / +110°C	-20°C / +130°C
CSM (Type Hypalon®)	+4°C / +80°C	-20°C / +110°C
FPM (Type Viton®)	-10°C / +170°C	-20°C / +200°C
Silicone	-20°C / +170°C	-40°C / +200°C
Nitrile (NBR)	-10°C / +80°C	-20°C / +90°C

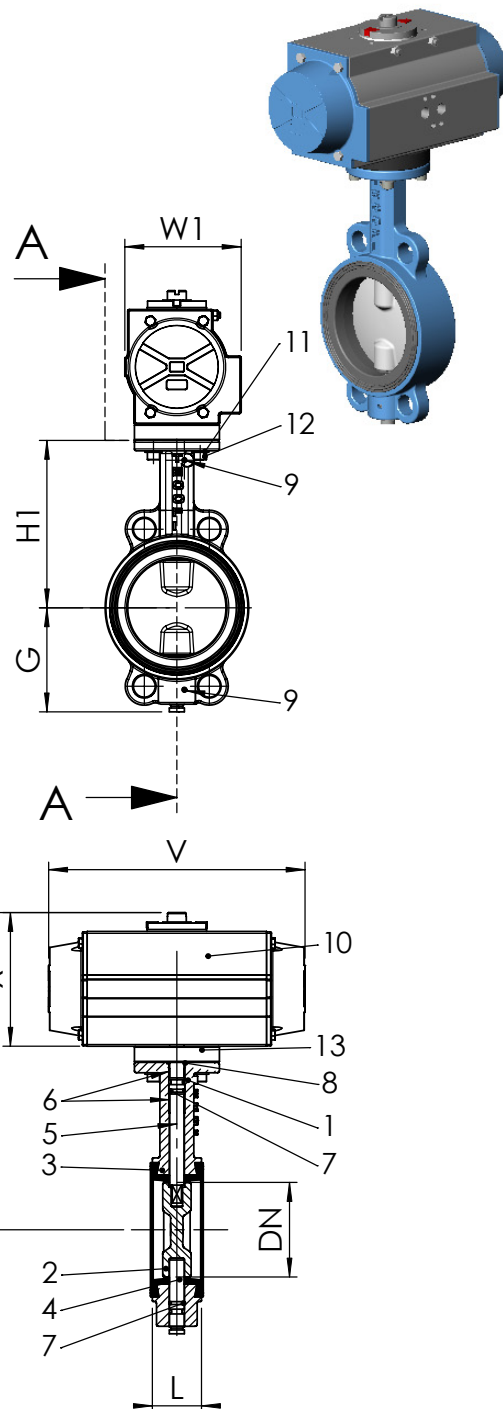

STANDARDS

Manufacture according to the requirements of the European directive 97/23/CE «Equipments under pressure» : fluids category III modulate H.
Pressure test according to standards EN 12266-1, DIN 3230, BS 6755 and ISO 5208 :
Body : 24 bar.
Seat : 17,6 bar.
Face to face according to standard NF EN 558-1 serie 20, ISO 5752 serie 20, DIN 3202.
Mounting between flanges PN10 / PN16 : according to EN 1092-2, BS450, ANSI B16.1-5.
Adjustable between flanges ASA 150.

5, impasse Pascal - Z.I. - BP 177 - 69686 CHASSIEU Cedex - FRANCE
Tél. +33 (0) 4 72 79 05 79 - Fax +33 (0) 4 78 90 19 19 / +33 (0) 4 72 79 05 70
E-mail : tecofi@tecofi.fr - Service commercial / Sales dep. : sales@tecofi.fr - www.tecofi.fr